

Darlington transistors with built-in temperature compensation diodes for audio amplifier applications

SAP series

MN15N/MP15Pの参考資料として、SAP15N/SAP15Pのデータシートを掲載しています。あくまで参考資料として、デバイス使用時には十分な検証、実験を行ってください。

Features

- Built-in temperature compensation diodes and one emitter resistor
- Real time temperature compensation
The temperature compensation diodes are mounted on one chip and placed in the center of the chip to detect temperature rises directly.
- Elimination of the temperature dependency of the idling current
The temperature coefficient of the diodes is optimized to have the idling current stabilized; thus one of the fatal failure modes in conventional Darlington transistors, Thermal Runaway, is avoidable.
- Symmetrical design for the PNP and the NPN pinouts
The new design minimizes the length of the pattern layout, and output distortions are controlled.
- Darlington transistors, temperature compensation diodes and one emitter resistor are incorporated in one package, so labor for parts insertion as well as the parts count is reduced.

MN15N/MP15Pでは、等価回路図中のエミッタ抵抗がオープンとなっております。アンプを構成する際には、エミッタ抵抗を外付けしてください。

Line up

Part Number	P _C (W)	V _{CEO} (V)	I _C (A)	h _{FE}	Emitter resistor (Ω)
SAP15P/SAP15N	150	160	15	5000 to 20000	0.22
SAP10P/SAP10N	100	150	12	5000 to 20000	0.22
SAP08P/SAP08N	80	150	10	5000 to 20000	0.22

External Dimensions (Unit : mm)

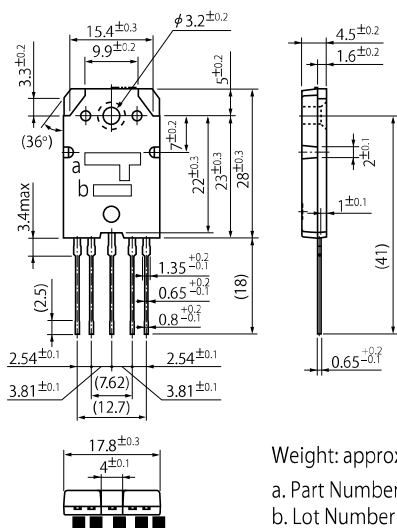

Equivalent Circuit Diagram

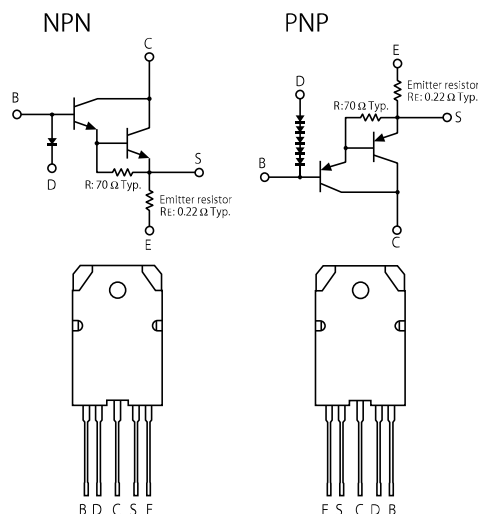

Application Information

1. Recommended Operating Conditions

- ① Add a variable resistor (VR) between diode terminals to adjust the idling current. The resistor having 0 to 200Ω is to be used.
- ② Adjust the forward current flowing over the diodes at 2.5mA.
- ③ Adjust the idling current at 40mA with the external variable resistor.

Both the temperature coefficients for the transistor and the diodes are matched under the above conditions. Both the PNP and the NPN are Darlington transistors, so the temperature change ratio of the total four V_{BE} of the transistors is subject to the compensation. One PN junction diode in the NPN and five Schottky barrier diodes in the PNP are built-in, and the total six diodes are operating as the temperature compensation.

The temperature coefficient of the total diodes (its variable value) becomes smaller with a larger forward current (approximately $-0.2\text{mV}/^\circ\text{C}$ to 1mA), and the coefficient of the total transistors (its variable value) also becomes smaller with a larger idling current (approximately $-0.1\text{mV}/^\circ\text{C}$ to 10mA), but the both variable values are small.

Thus, the distortion of the temperature coefficient caused by the different current is small, so the thermal runaway may not be occurred due to the changes of the recommended ratings; however, the actual operation is to be confirmed by using an experimental equipment or board.

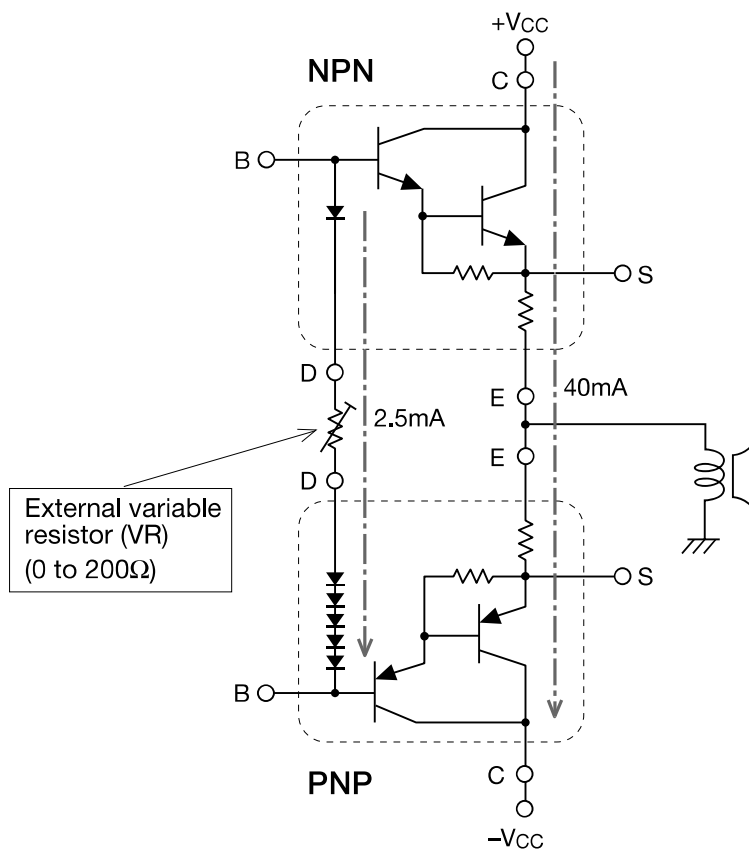

2. External Variable Resistor

Total forward voltage (at $I_F=2.5\text{mA}$) of the diodes is designed to be equal or less than that of total V_{BE} (at $I_C = 40\text{mA}$) of the transistor, thus the idling current is required to be adjusted at 40mA with an additional external variable resistor.

The relations are shown as below:

$$\text{Total } V_F \text{ of Diode} \leq \text{Total } V_{BE} \text{ of Transistor} + \text{Total } V_{RE} \text{ of Emitter Resistor}$$

$$\Delta V=0 \text{ to } 500\text{mV}$$

The V_{BE} of the transistor is dependent to the h_{FE} , and the V_{BE} is lower with higher h_{FE} and vice versa. The h_{FE} for both the PNP and the NPN varies between $5k$ and $20k$; thus the V_{BE} is the lowest with the combination of maximum h_{FE} ($20k$) each and it is the highest with the combination of minimum h_{FE} ($5k$) each.

Presuming the voltage difference between the V_F of the diodes and the V_{BE} of the transistors (including the total voltage drops of the two emitter resistors) as ΔV .

$$\text{Minimum } V_{BE} - \text{Maximum } V_F \text{ variations of the diodes} = 0$$

$$\text{Maximum } V_{BE} - \text{Minimum } V_F \text{ variations of the diodes} = 500\text{mV}$$

The current flowing over the diodes and the V_R is adjusted at 2.5mA ; therefore

$$500\text{mV} \div 2.5\text{mA} = 200\Omega$$

Consequently, the applicable V_R value is to be 0 to 200Ω

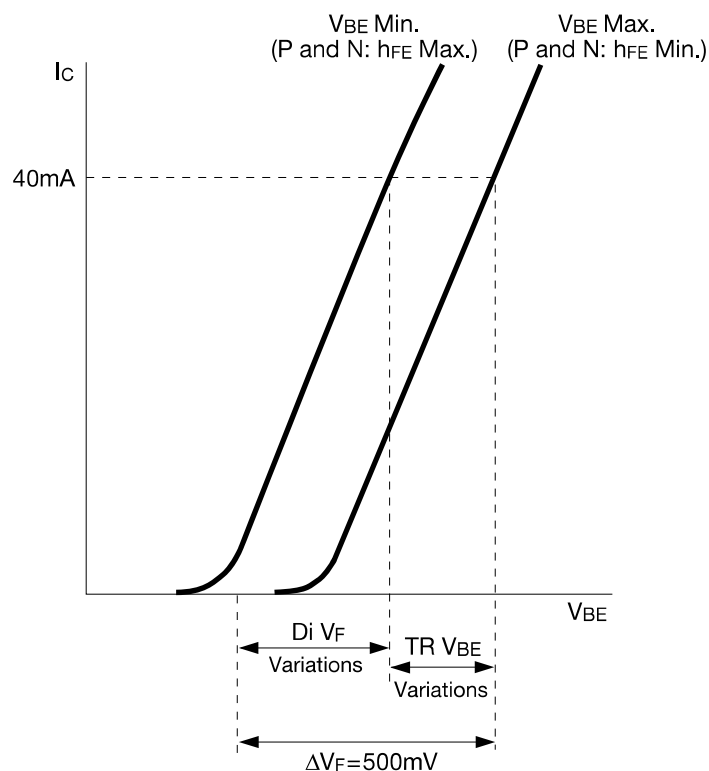

3. Characteristics of the temperature compensation diodes

The several temperature compensation diodes are connected in series, so the forward voltage is varied with small current fluctuations. Therefore, in case the forward current flowing over the diodes is set at 2.5mA and over, the forward voltage rises, and in the worst combinations, the idling current reaches to 40mA and over with minimum V_R of 0Ω . On the contrary, in case the forward current is set at 2.5mA or below, the idling current may not reach to 40mA with maximum V_R of 200Ω .

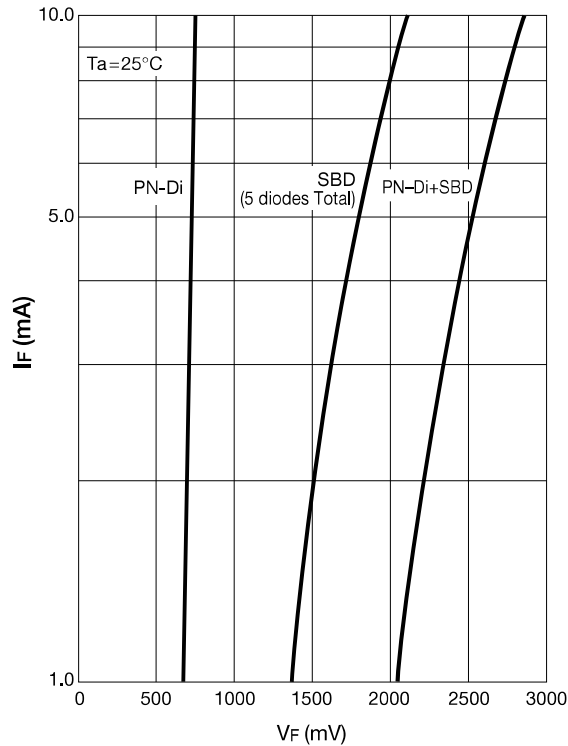

$I_F - V_F$ Characteristics

4. Parallel push-pull application

Adjustments of the idling current are required by each the resistor in parallel push-pull applications. One side adjustment will cause the idling current to be unstable (seesaw operation) because of the different h_{FE} .

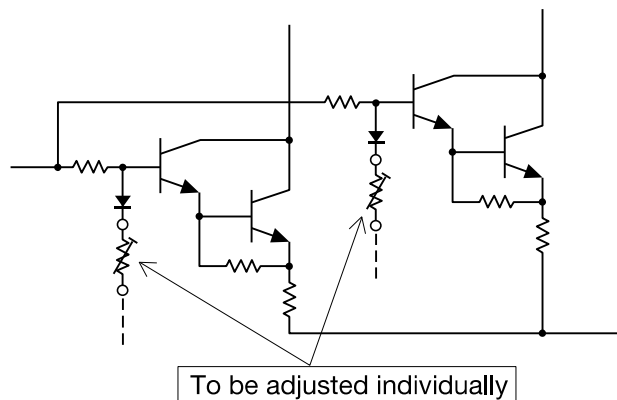

5. Destruction capacity of the built-in emitter resistor

The built-in resistor is fabricated with polysilicone on the chip for the SAP08P/N and a thick-film resistor is used for the SAP10P/N and SAP15P/N. The latter, the thick-film resistor, has weaker destruction point in the P_c area (especially for large current flowing area) rather than that of the transistor chip itself. This is subject to the area beyond Safe Operating Area (S.O.A).

However, under the evaluation like a short circuit test in which the current exceeds the guaranteed value, it may cause the emitter resistor to be destroyed before the transistor itself is destroyed.

Consequently, the current value (or time) that operates the protection circuit is to be set at lower than that of discrete device configurations. In the application of car audio amplifiers, the same manners as the above need to be considered because the large current is flowed at low impedance.

In addition, once the transistor falls into thermal runaway due to a soldering failure to the external VR added between diodes or other failure manners, as the worst case, there may cause a resin crack or smoke emissions by flare up. Flame retardant molding resin is used, and the material of the product is conformed to the most sever standard UL94V0. However it is recommended that the careful consideration be given to a protection circuit, and the protection circuits should be provided appropriately in due course.

If the operating conditions are not to be matched to the ratings, it is also recommended that the E (Emitter resistor) terminal should be opened and the external emitter resistor should be added to the S (Sensing) terminal shown as below. (However this is not applicable to the SAP08P/N because a thin inner lead is used for S terminal.)

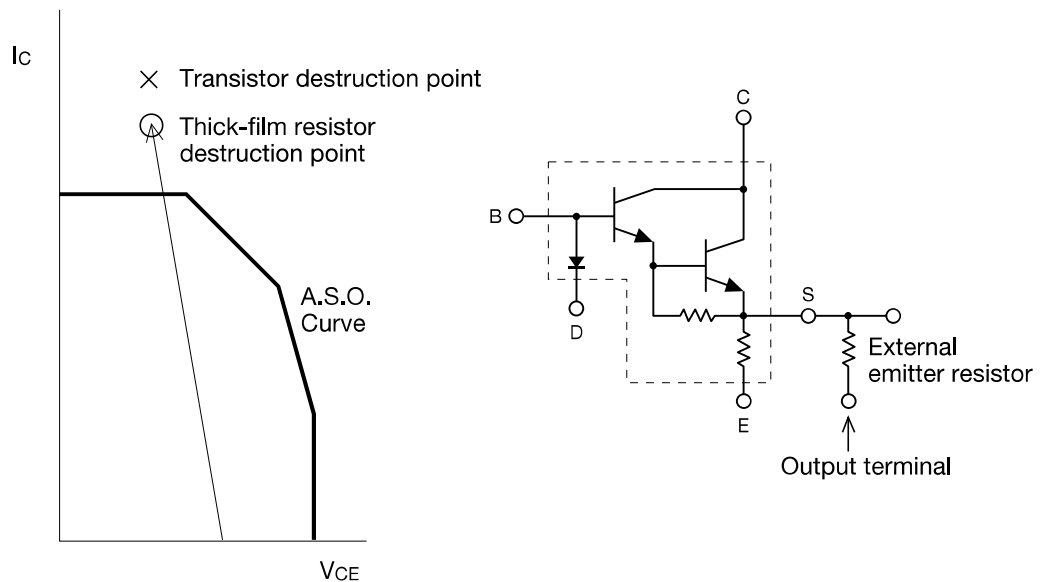

Built-in temperature compensation diodes
Built-in emitter resistor
Darlington

SAP15N

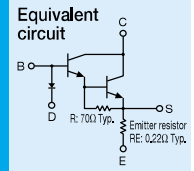

(Complement to type SAP15P)

Application: Audio

Absolute maximum ratings ($T_a=25^\circ\text{C}$)

Symbol	Rated	Unit
V_{CB0}	160	V
V_{CEO}	160	V
V_{EBO}	5	V
I_C	15	A
I_B	1	A
P_C	150 ($T_C=25^\circ\text{C}$)	W
$D_i I_F$	10	mA
T_j	150	$^\circ\text{C}$
T_{stg}	-55 to +150	$^\circ\text{C}$

Electrical Characteristics ($T_a=25^\circ\text{C}$)

Symbol	Conditions	Ratings			Unit
		min	typ	max	
I_{CB0}	$V_{CB}=160\text{V}$			100	μA
I_{EBO}	$V_{EB}=5\text{V}$			100	μA
V_{CEO}	$I_C=30\text{mA}$	160			V
h_{FE}^*	$V_{CE}=4\text{V}, I_C=10\text{A}$	5000		20000	
$V_{CE(sat)}$	$I_C=10\text{A}, I_B=10\text{mA}$			2.0	V
$V_{BE(sat)}$	$I_C=10\text{A}, I_B=10\text{mA}$			2.5	V
V_{BE}	$V_{CE}=20\text{V}, I_C=40\text{mA}$		1190		mV
$D_i V_F$	$I_F=2.5\text{mA}$		705		mV
R_E	$I_E=1\text{A}$	0.176	0.22	0.264	Ω

*Rank O (5000 to 12000), Y (8000 to 20000)

External Dimensions

(Unit: mm)

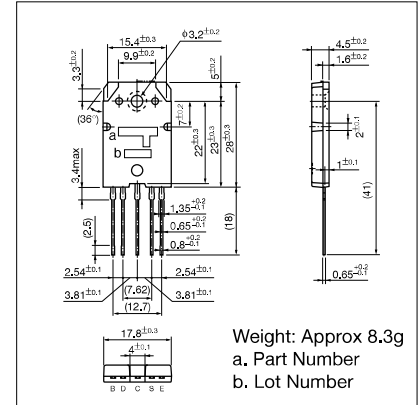

$I_C - V_{CE}$ Characteristics (Typical)

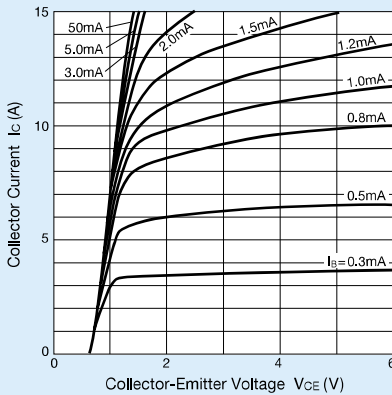

$V_{CE(sat)} - I_B$ Characteristics (Typical)

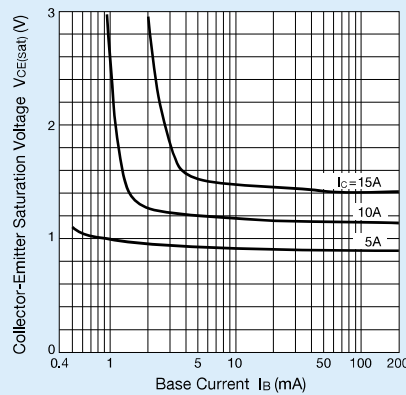

$I_C - V_{BE}$ Temperature Characteristics (Typical)

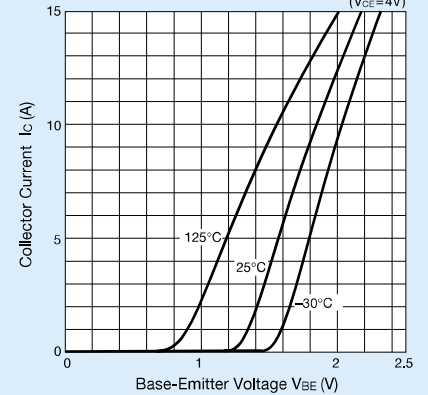

$h_{FE} - I_C$ Characteristics (Typical)

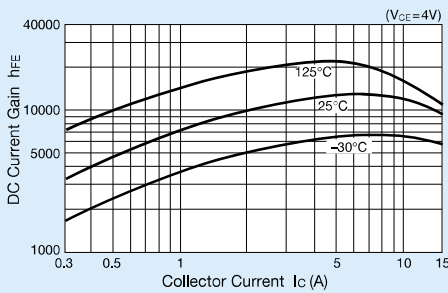

$\theta_{ja} - t$ Characteristics

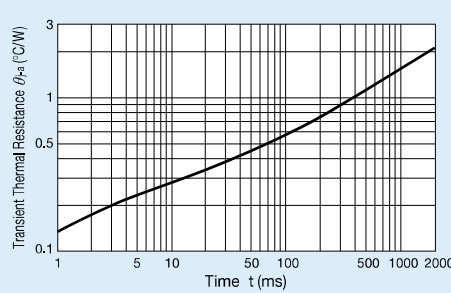

Safe Operating Area (Single Pulse)

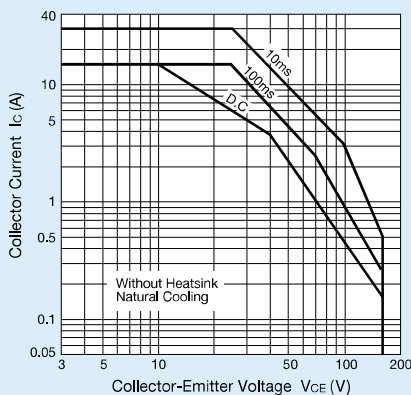

$D_i I_F - V_F$ Characteristics (Typical)

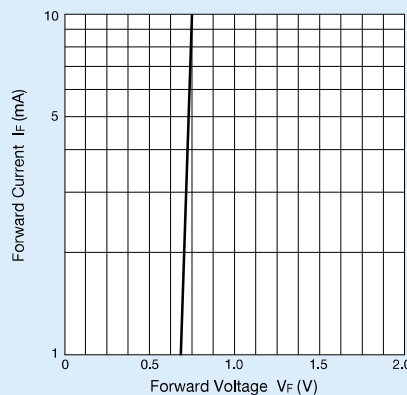

$P_C - T_a$ Derating

